



EQUIPMENT STAND ASSEMBLY GUIDE
(PLEASE READ CAREFULLY BEFORE ASSEMBLING)

NOTE:

EACH M6 BOLT IS EQUIPPED WITH A NYLON WASHER. ENSURE TO TIGHTEN IT AGAINST THE SIDE OF THE BOLT FLANGE.

STEP 1—BOLT TOGETHER THE SHORTER BRACKET WITH 2 LEGS AS SHOWN BELOW. REPEAT TO FASTEN TOGETHER THE OTHER END.

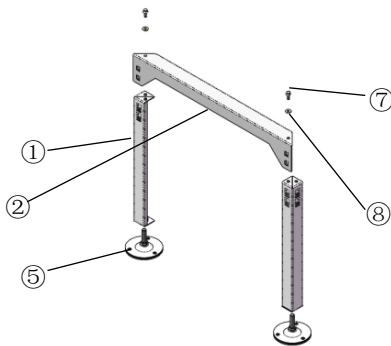

STEP 2—BOLT ON BOTH SIDES OF THE ASSEMBLED ENDS OF THE LONGER BRACKETS AS SHOWN BELOW TO FORM THE STAND.

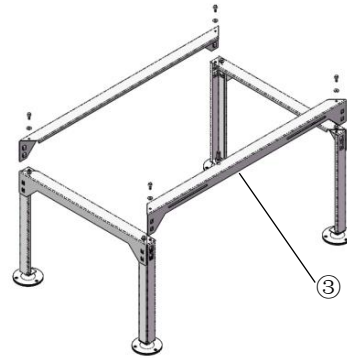

STEP 3—BOLT THE 2 ADJUSTABLE BRACKETS ON TOP OF THE STAND AS SHOWN BELOW.

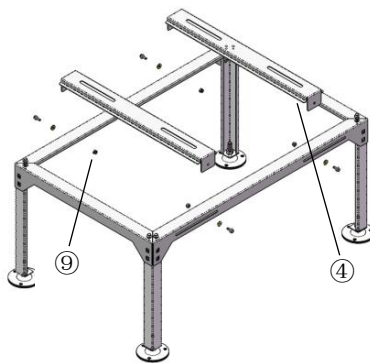

STEP 4— FIND SOLID, LEVEL GROUND TO PLACE THE STAND AND SECURE IT TO THE GROUND OR MOUNTING BASE.

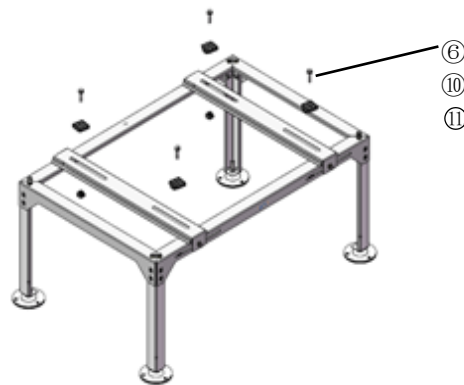

ITEM	DESCRIPTION	SIZE	QTY	ITEM	DESCRIPTION	SIZE	QTY
1	Columns	Q235A 2.0mm	2	7	Bolt	M6 * 16	12
2	Beam	Q235A 2.0mm	2	8	Nylon Washer	Φ6*16*2	12
3	Middle Beam	Q235A 2.0mm	2	9	Locking Nut	M6	4
4	Support-Top	Q235A 2.0mm	4	10	Rubber Pad	40*40*8	4
5	Foot-adjustable	HTZJ-580B	4	11	Rubber Insert	M8	4
6	Bolt	M8 * 35	4				



Release and Waiver of Liability

This Release and Waiver of Liability (“Release”) is executed by the undersigned (“Buyer” or “Installer”) in favor of **Goldstone HVACR Inc.**, a corporation organized and existing under the laws of Ontario, with its principal place of business at 272 Prospect St., St. George, ON, N0E 1N0, including its directors, officers, employees, and agents (collectively, “the Company”).

1. Waiver and Release:

The Buyer or Installer, on behalf of themselves and their personal representatives, assigns, heirs, and next of kin, hereby fully releases and forever discharges the Company from any and all liability, claims, and demands of whatever kind or nature, either in law or in equity, that arise from any misuse, unauthorized modification, out-of-scope usage, redevelopment, or reverse engineering of the products provided by the Company. The Buyer or Installer understands and agrees that this Release discharges the Company from any liability or claim that they may have against the Company for damages arising from such actions.

2. Assumption of Risk:

The Buyer or Installer acknowledges and agrees that any misuse, out-of-scope use, modification, redevelopment, or reverse engineering of the Company's products is carried out at their own risk. The Company does not warrant any outcomes resulting from these actions, and the Buyer or Installer assumes full responsibility for any resulting damages, injuries, or losses.

3. Compliance with Local Laws and Regulations:

It is the sole responsibility of the Buyer or Installer to ensure that the installation or application of the product(s) complies with all relevant local codes, laws, and regulations. The Company assumes no responsibility for any consequences arising from non-compliance with these requirements.

4. Indemnification:

The Buyer or Installer agrees to indemnify and hold harmless the Company from and against any and all claims, damages, losses, and expenses, including legal fees, arising from the misuse, out-of-scope use, modification, redevelopment, or reverse engineering of the Company's products.

5. Acknowledgment of Understanding:

The Buyer or Installer acknowledges that they have read and fully understand this Release and, they accept the terms and conditions of this release when the purchase is completed.

Goldstone HVACR Inc.

272 Prospect St. | St. George, ON | N0E 1N0

Toll Free: 1.866.508.0303 | Office: 519.448.1448 | Fax: 519.448.4884

JY-04

